

# commercial components for the digital optical link

evaluation status and prototype // th.bauer , f.vasey, m.pernicka

reviewed and updated version (04.03.2001)

**why commercial transceivers**

- FEC side of the link does not have to be radiation tolerant
- difficult laser biasing of CERN transmitter (no automatic power control)
  - monitoring the state of the laser using the (irradiated) pin diode on the experiment side is unreliable.
- commercial components possibly cheaper / simpler than radhard TRX (+development of APC)

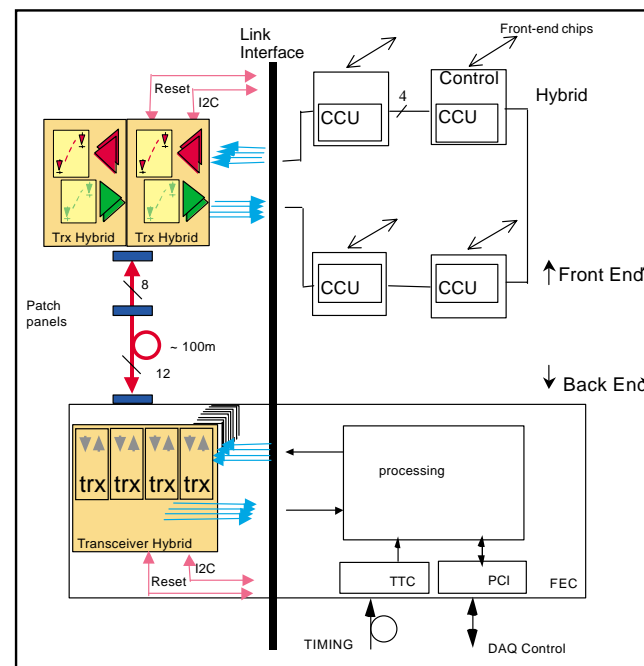

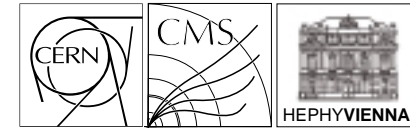

Market

**overview**

manufacturer	typecode	size	speed	type	connector	level	~ price/ch	available	tested
LUCENT	1417K4A	SFF	2.5Gb/s	TRX	LC Duplex	LVPECL	710\$		
	1417G4A	SFF	155Mb/s	TRX	LC Duplex	LVPECL	220\$	hopeless	
AMP	269086-1	w:25.4 h:9.8	156Mb/s	TRX	SC Duplex	PECL	140\$	2	✓
	269085-1	w:25.4 h:9.8	125Mb/s	TRX	SC Duplex	PECL	140\$	2	✓
AGILENT	HFCT-5215B/D	w:25.4 h:9.8	155Mb/s	TRX	SC Duplex	LVPECL	280\$		
	HFCT-5905E	SFF	155Mb/s	TRX	MT RJ	LVPECL	280\$	2	✓
	HFCT-5903E	SFF	125Mb/s	TRX	MT RJ	LVPECL	230\$	1	✓
	HFCT-5201A	w:25.4 h:9.8	155Mb/s	TRX	SC Duplex	LVPECL	400\$	2	✓
INFINEON	V23818-N15-L17	SFF	2.5Gb/s	TRX	LC Duplex	LVPECL	500\$	2	✓
SUMITOMO	scm6001glb scm6101gla1 scm6201b.pdf	SFF	155Mb/s	TRX	LC Duplex	LVPECL		mid 2001	
METHODE	MLC-25-4-2-TL	SFF	1.25Gb/s	TRX	LC Duplex	LVPECL	280\$	1	
	SF3-LT12H	SFF	700Mb/s	TRX	LC Duplex	LVPECL	260\$		
	SF2-LT12H	SFF	200Mb/s	TRX	LC Duplex	LVPECL	200\$	2	✓
HITACHI	MDS/R2211A (product cancelled)		200Mb/s	12*Tx->Rx	MPO		1000\$/500\$ no red./ red.	1	
OPTOBAHN	(product under dev.)			4*Tx<->Rx	MPO		650\$/325\$ no red./ red.	Apr 01	

digital optical link prototype

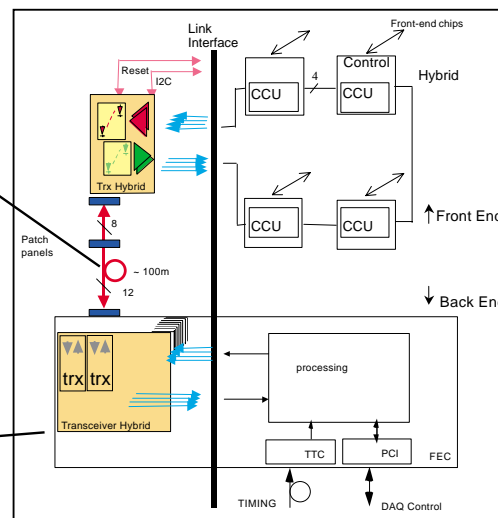
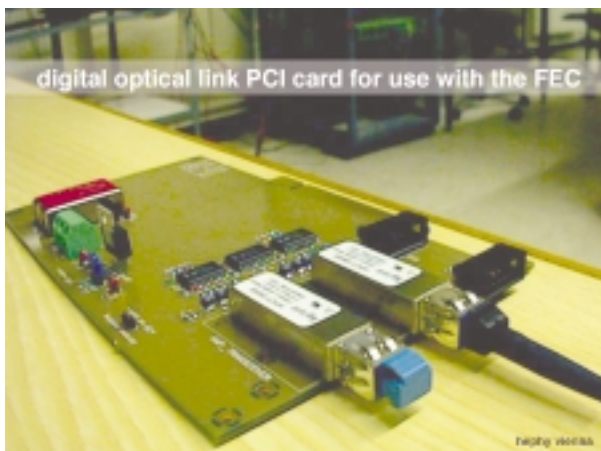

- 2 transceivers (4 channels; no redundancy)
- can be used in a PCI slot (power supply from pci bus)
- also available in separate case with external power supply
- designed for various transceiver types
- interfaces to FEC PMC card

**AVAILABILITY**

- within 2 weeks
- how many: 10
- price (including fiber patch cable):  
 1650 sfr  
 1720 sfr (in separate box + power supply)

**PCI card in test setup**

- basic tests finished
- test using PCI card together with FEC / CCU currently in progress
- optolink PCI card on CCU side will be exchanged to optohybrid as soon as it becomes available.

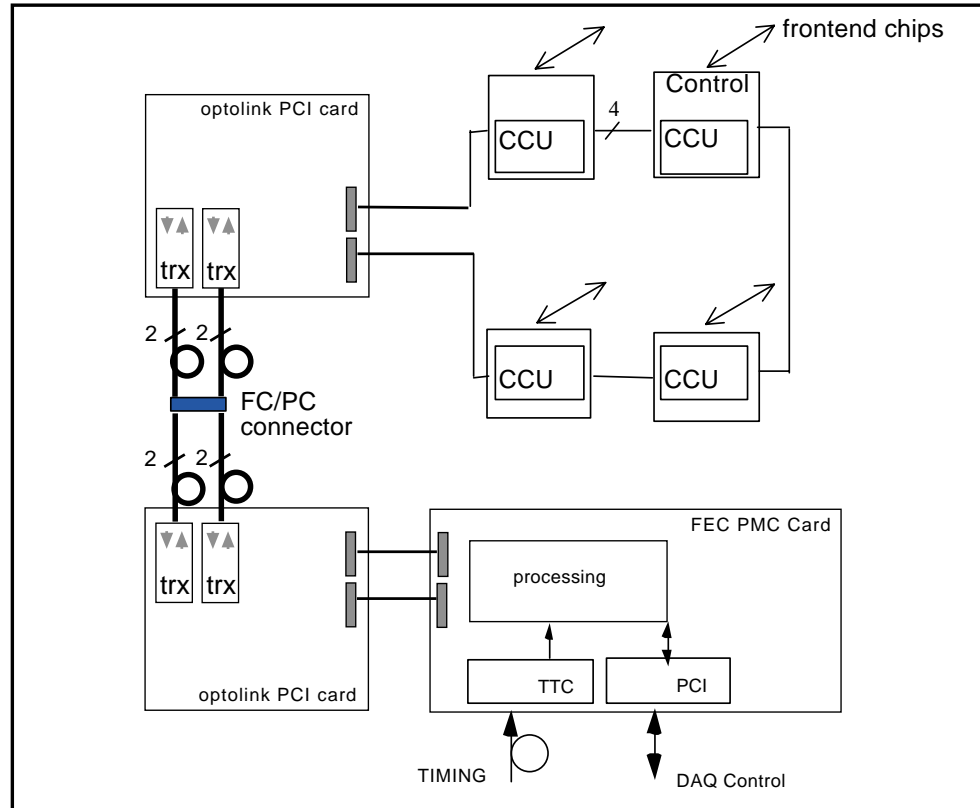

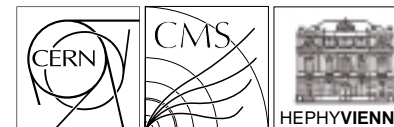

contact

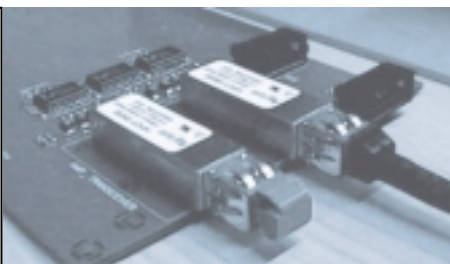

**CONTACT: Institute for High Energy Physics  
Vienna / Austria**

**e-mail: [thomas.bauer@cern.ch](mailto:thomas.bauer@cern.ch)  
[pernicka@hephy.oeaw.ac.at](mailto:pernicka@hephy.oeaw.ac.at)**

more information:

**<http://cern.ch/bauer>**

[thomas.bauer@cern.ch](mailto:thomas.bauer@cern.ch)